

REVISION				
REV	DESCRIPTION	BY	DATE	CHANGE NO.
1	NOTES & DESCRIPTION UPDATED	JL	01/10/14	CBH-

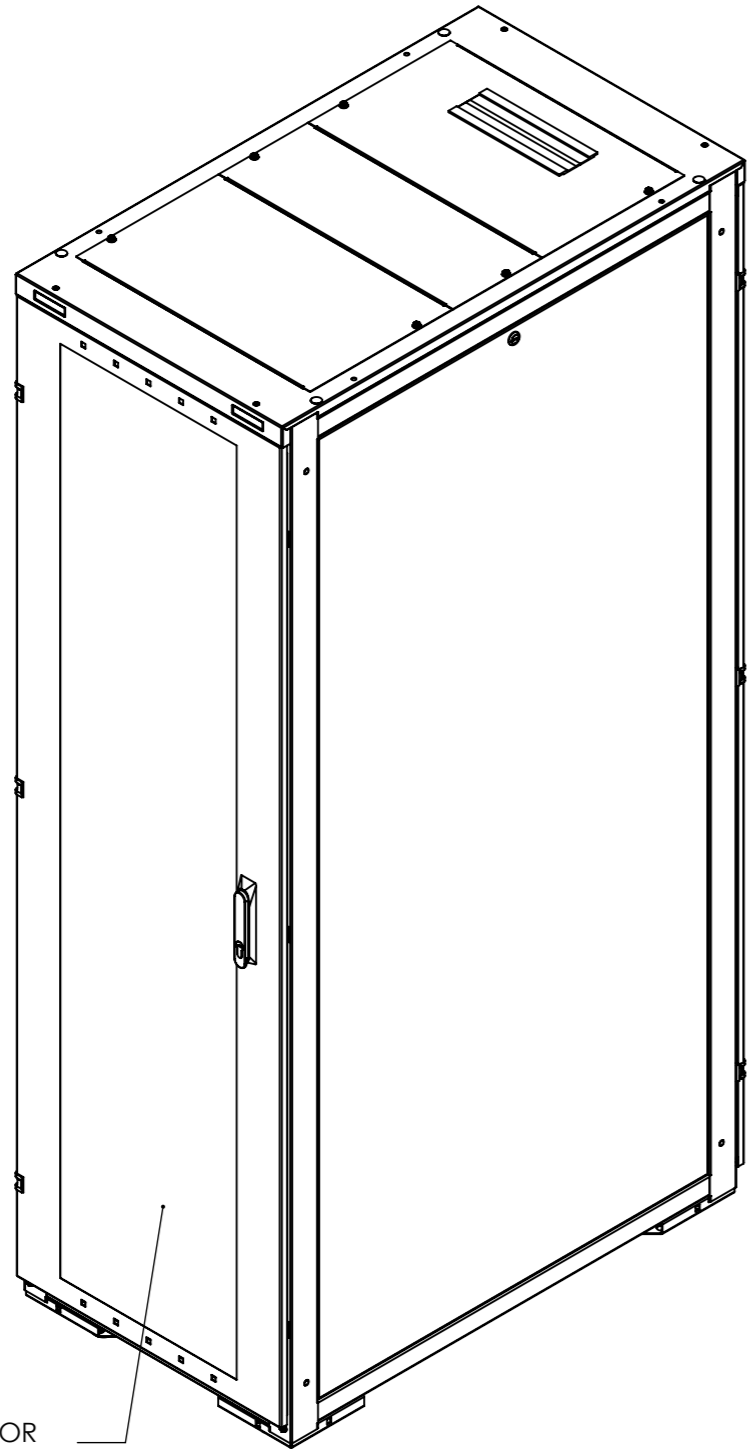

PERFORATED FRONT DOOR

FRONT ISO

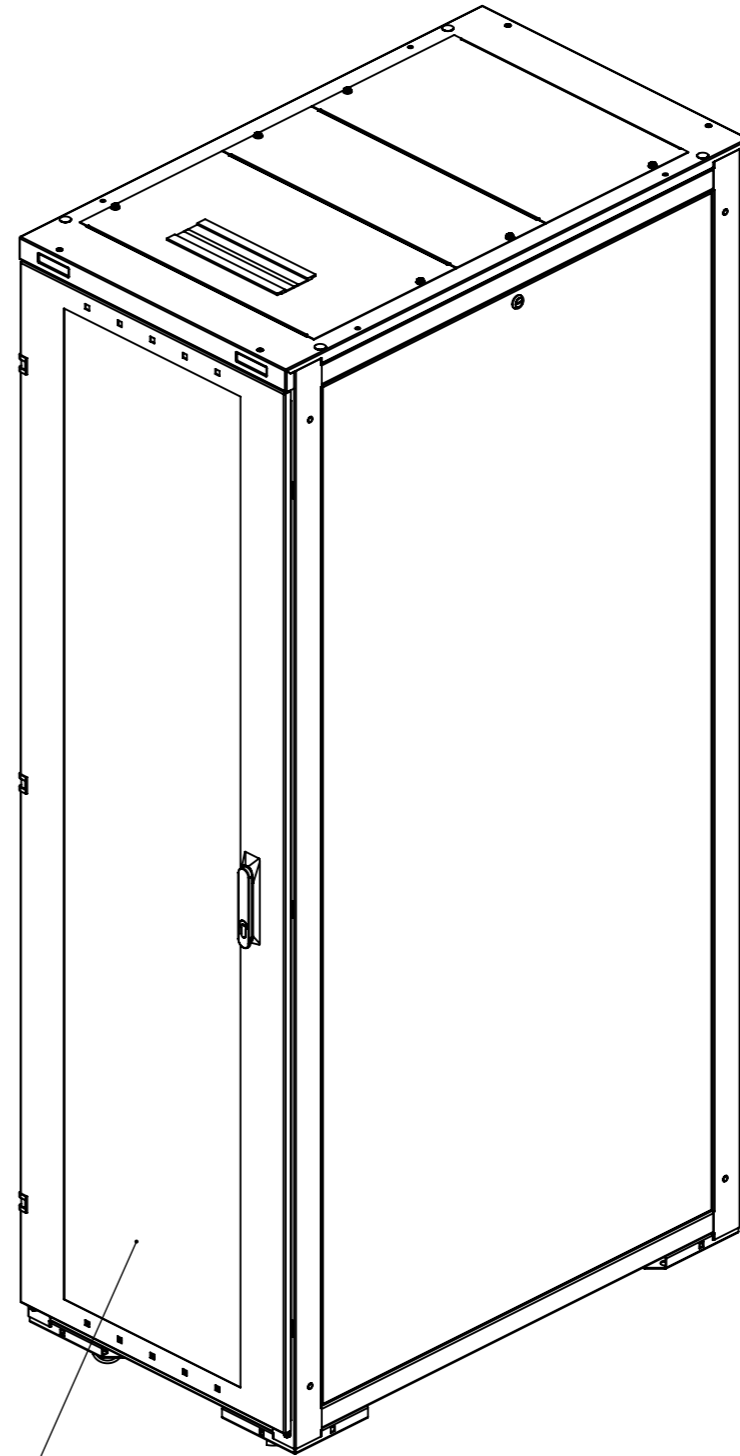

PERFORATED REAR DOOR

REAR ISO

 Powering Business Worldwide Walrow Industrial Estate Highbridge, Somerset England TA9 4AQ Phone +44 (0) 1278 783371 FAX +44 (0) 1278 789037 www.cooperline.com	TITLE: REC SERIES RACK 42U & 47U 600w PERFORATED DOORS RCA42610SPBE / RCA42612SPBE RCA47610SPBE / RCA47612SPBE		REFERENCE DWG(S):	SUBMITTAL NO: S00024952
	EQUIPMENT FURNISHED HAS BEEN FABRICATED IN ACCORDANCE WITH THIS DRAWING.		MODEL SOURCE FILE: 00024952	REV: 00
	DATE: 17/09/14		DRAWN BY: JL CHECKED BY: GGB REV: 1	SHEET: 1 OF 3
	THIS DRAWING AND/OR THE TECHNICAL INFORMATION CONTAINED HEREON IS THE PROPERTY OF COOPER B-LINE, INC. (B-LINE), AND IS ISSUED IN CONFIDENCE FOR B-LINE ENGINEERING PURPOSES ONLY AND MAY NOT BE REPRODUCED OR USED FOR ANY PURPOSE WHATSOEVER WITHOUT THE EXPRESS WRITTEN PERMISSION OF B-LINE TO THE USER. THIS DRAWING AND/OR TECHNICAL INFORMATION IS THE PROPERTY OF B-LINE AND IS LOANED FOR MUTUAL ASSISTANCE, TO BE RETURNED WHEN ITS INTENDED PURPOSE HAS BEEN SERVED.			

B-Line by Eaton Commerce Way, Highbridge, Somerset TA9 4AQ - United Kingdom		EATON	
IT-RACK	RCA426**SPBE		
CE	SN:	Made In The UK	
	EIA-310-E & IEC60950	2014	
UPC			

EXAMPLE EATON SERIAL LABEL

LOCATED INSIDE CABINET
CENTRALISED AT THE FRONT
ON THE UNDERSIDE OF THE
TOP PANEL
(SEE LOCATION HIGHLIGHTED
ON FRONT VIEW *)



EXAMPLE EATON LOGO LABEL

LOCATED TOP LEFT OF CABINET FRAME
FRONT AND REAR
(SEE LOCATION HIGHLIGHTED
ON FRONT VIEW **)

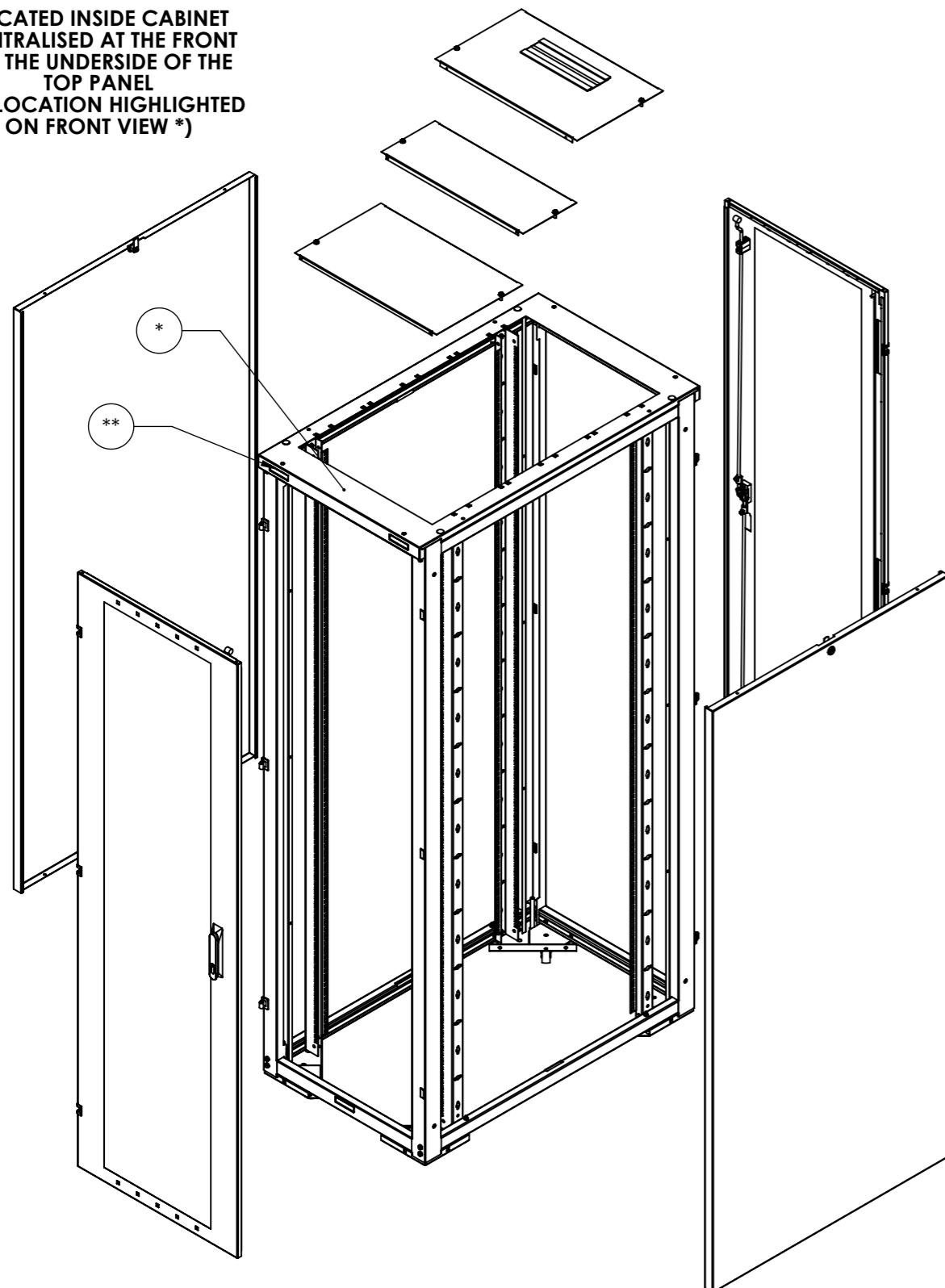

REVISION				
REV	DESCRIPTION	BY	DATE	CHANGE NO.
1	NOTES & DESCRIPTION UPDATED	JL	01/10/14	CBH-

SPECIFICATION :

- : BASIC FRAME WITH JACKING FEET & CASTORS
- : 2 X PAIRS OF FULLY ADJUSTABLE 19-INCH RAILS
- : UNIT HEIGHT LABELS (FRONT & REAR, BOTTOM TO TOP)
- : PERFORATED STEEL FRONT DOOR WITH 3-POINT LOCKING SWING HANDLE (80% PERFORATED AREA)
- : PERFORATED STEEL REAR DOOR WITH 3-POINT LOCKING SWING HANDLE (80% PERFORATED AREA)
- : SIDE PANELS (PAIR)
- : TOP COMPRISING OF 1 X BRUSH PANEL (REAR), ALL OTHERS PLAIN PANELS
- : SUPPLIED WITH EARTH KIT (LOOSE)
- : SUPPLIED WITH FIXING KIT
- : BAYING KIT
- : STATIC LOAD RATING - 1100KG
- : FINISHED BLACK RAL9005
- : SUPPLIED FULLY ASSEMBLED
- : ON HEAT TREATED EURO PALLET

<small>THIS DRAWING AND/OR THE TECHNICAL INFORMATION CONTAINED HEREON IS THE PROPERTY OF COOPER B-LINE, INC. ("B-LINE"), AND IS ISSUED IN CONFIDENCE FOR B-LINE ENGINEERING PURPOSES ONLY AND MAY NOT BE REPRODUCED OR USED FOR ANY PURPOSE WHATSOEVER WITHOUT THE EXPRESS WRITTEN PERMISSION OF B-LINE TO THE USER. THIS DRAWING AND/OR TECHNICAL INFORMATION IS THE PROPERTY OF B-LINE AND IS LOANED FOR MUTUAL ASSISTANCE. TO BE RETURNED WHEN ITS INTENDED PURPOSE HAS BEEN SERVED.</small>		REFERENCE DWG(S):	SUBMITTAL NO: S00024952
 Powering Business Worldwide Walrow Industrial Estate Highbridge, Somerset England TA9 4AQ Phone +44 (0) 1278 783371 FAX +44 (0) 1278 789037 www.cooperline.com	TITLE: REC SERIES RACK 42U & 47U 600w PERFORATED DOORS RCA42610SPBE / RCA42612SPBE RCA47610SPBE / RCA47612SPBE	DRAWN BY: JL	CHECKED BY: GGB
	DATE: 17/09/14		REV: 1
EQUIPMENT FURNISHED HAS BEEN FABRICATED IN ACCORDANCE WITH THIS DRAWING.		MODEL SOURCE FILE: 00024952	REV: 00
		SHEET: 2 OF 3	

S00024952

REVISION				
REV	DESCRIPTION	BY	DATE	CHANGE NO.
1	NOTES & DESCRIPTION UPDATED	JL	01/10/14	CBH-

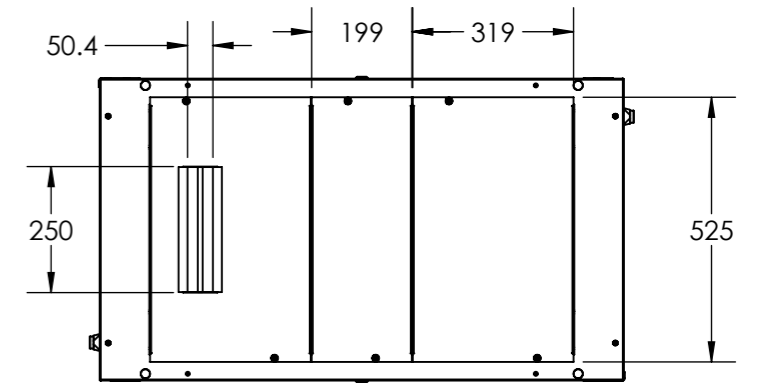
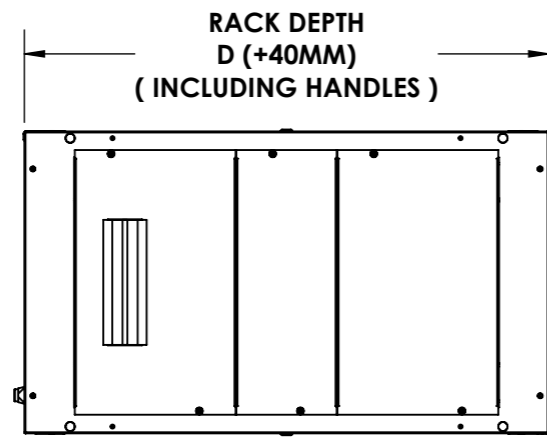

1000 TOP CONFIGURATION

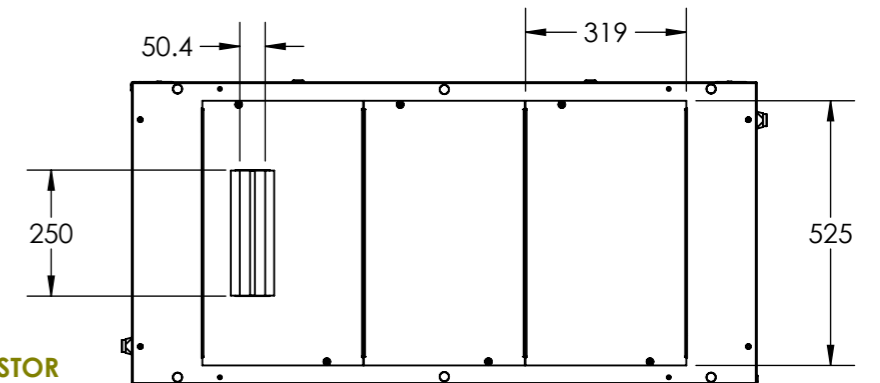

1200 TOP CONFIGURATION

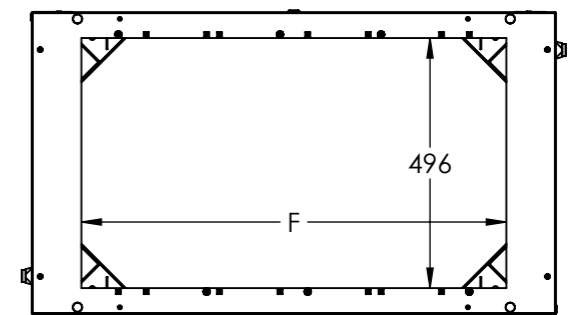

OPEN TOP SIZE

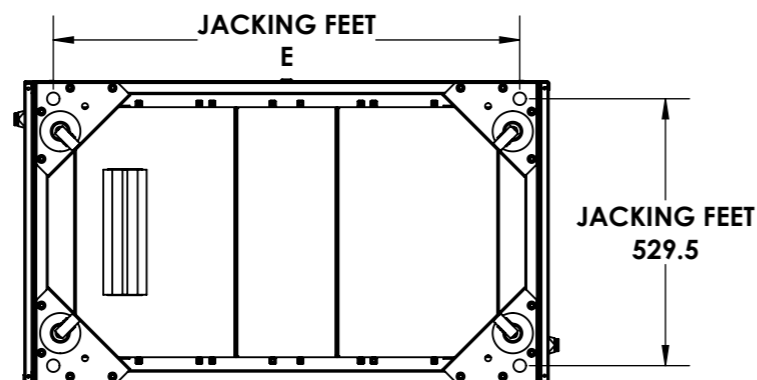
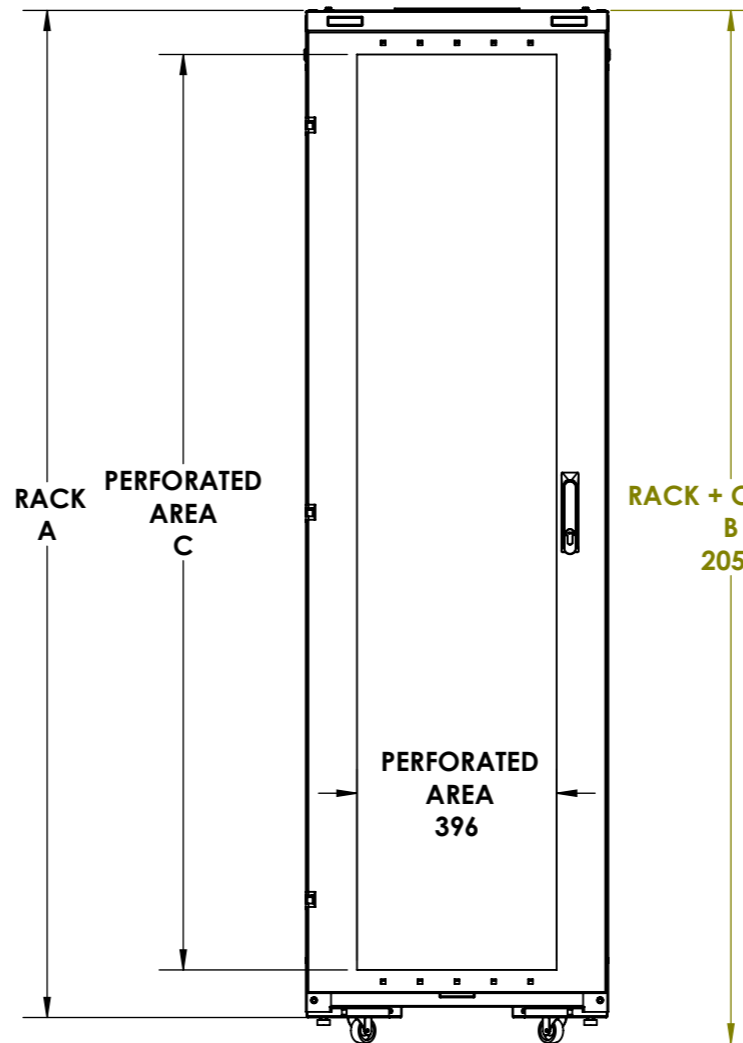
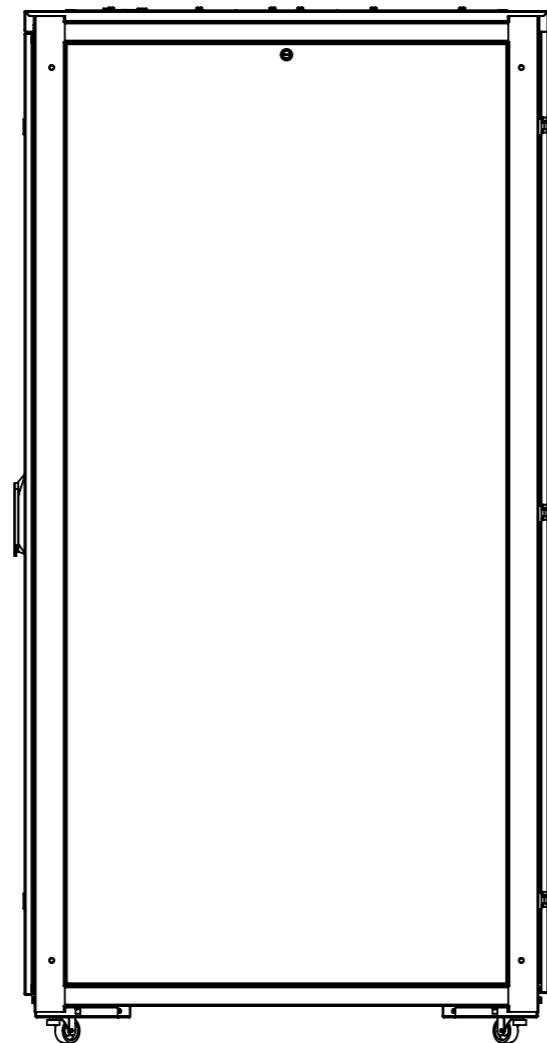
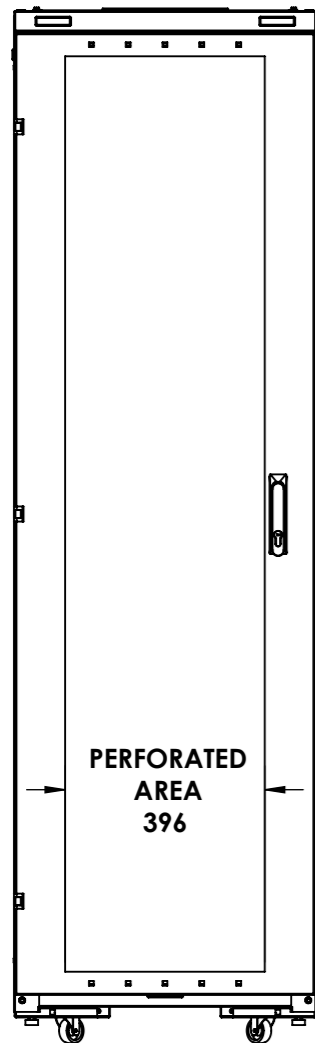

PART No.	U. HEIGHT	DIM.'A'	DIM.'B'	DIM.'C'	DIM.'D'	DIM.'E'	DIM.'F'	WEIGHT
RCA42610SPBE	42U	1998mm	2049mm	1816mm	1040mm	925mm	843mm	109Kg
RCA42612SPBE	42U	1998mm	2049mm	1816mm	1240mm	1125mm	963mm	118Kg
RCA47610SPBE	47U	2220mm	2271mm	2033mm	1040mm	925mm	843mm	118Kg
RCA47612SPBE	47U	2200mm	2271mm	2033mm	1240mm	1125mm	963mm	129Kg

THIS DRAWING AND/OR THE TECHNICAL INFORMATION CONTAINED HEREON IS THE PROPERTY OF COOPER B-LINE, INC. (B-LINE), AND IS ISSUED IN CONFIDENCE FOR B-LINE ENGINEERING PURPOSES ONLY AND MAY NOT BE REPRODUCED OR USED FOR ANY PURPOSE WHATSOEVER WITHOUT THE EXPRESS WRITTEN PERMISSION OF B-LINE TO THE USER. THIS DRAWING AND/OR TECHNICAL INFORMATION IS THE PROPERTY OF B-LINE AND IS LOANED FOR MUTUAL ASSISTANCE. TO BE RETURNED WHEN ITS INTENDED PURPOSE HAS BEEN SERVED.

Powering Business Worldwide
Walrow Industrial Estate
Highbridge, Somerset
England TA9 4AQ
Phone +44 (0) 1278 783371
FAX +44 (0) 1278 789037
www.cooperline.com

TITLE:
**REC SERIES RACK 42U & 47U 600w
PERFORATED DOORS**
RCA42610SPBE / RCA42612SPBE
RCA47610SPBE / RCA47612SPBE

REFERENCE DWG(S):

MODEL SOURCE FILE:
00024952

REVISION:

00

SUBMITTAL NO:
S00024952

DRAWN BY:	CHECKED BY:	REV:
JL	GGB	1

DATE:
17/09/14

SHEET:
3 OF 3

EQUIPMENT FURNISHED HAS BEEN FABRICATED IN ACCORDANCE WITH THIS DRAWING.